

### Building Sketch

Borrower/Client	Sullivan, Brian & Mary Beth				
Property Address	456 S Bundy Dr				
City	Los Angeles	County	Los Angeles	State	CA
Zip Code	90049				
Lender	US Bank				

THIS SKETCH IS FOR ILLUSTRATION PURPOSES ONLY  
MEASUREMENTS ARE APPROXIMATE

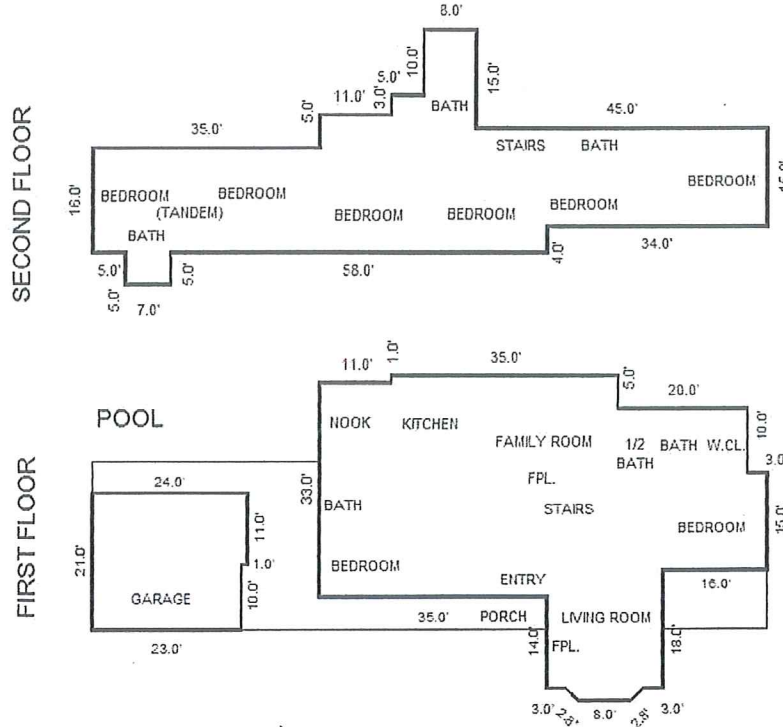

Drawn by: Aerial™

Comments

AREA CALCULATIONS SUMMARY			
Code	Description	Net Size	Net Totals
GLA1	First Floor	2398.0	2398.0
GLA2	Second Floor	1937.0	1937.0
GAR	Garage	494.0	494.0
Net LIVABLE Area		(Rounded)	4335

LIVING AREA BREAKDOWN			
Breakdown			Subtotals
<b>First Floor</b>			
	15.0 x	33.0	495.0
	15.0 x	16.0	240.0
	2.0 x	8.0	16.0
0.5 x	2.0 x	2.0	2.0
0.5 x	2.0 x	2.0	2.0
	10.0 x	28.0	280.0
	3.0 x	43.0	129.0
	5.0 x	11.0	55.0
	33.0 x	35.0	1155.0
	1.0 x	24.0	24.0
<b>Second Floor</b>			
	5.0 x	7.0	35.0
	13.0 x	20.0	260.0
	8.0 x	10.0	80.0
	11.0 x	17.0	187.0
	15.0 x	45.0	675.0
	12.0 x	35.0	420.0
	8.0 x	70.0	560.0
17 Items	(Rounded)		4335